

SUBMITTAL RECORD

JOB _____
 LOCATION _____
 SUBMITTED TO _____
 SUBMITTAL PREPARED BY _____
 APPROVED BY _____
 DATE _____



Submittal Form
Duro-Twist™
Regulator

DURO-TWIST™ REGULATOR

The Duro-Twist is a hand operated elevated regulator designed for use with square rod on both square and round externally insulated duct. It is offered in four standoff heights, 1", 1-1/2", 2" & 3". The Duro-Twist is engineered with a strong friction resistance so it stays set without any need to lock it in place. The high visibility yellow handle allows it to be easily found in the field on wrapped duct. The handle position illustrates damper blade position on the outside of the ductwork.

- Four Sizes: 1", 1-1/2", 2", 3"
- Manual operation (no tools)
- 10° angled stand for both square and round duct

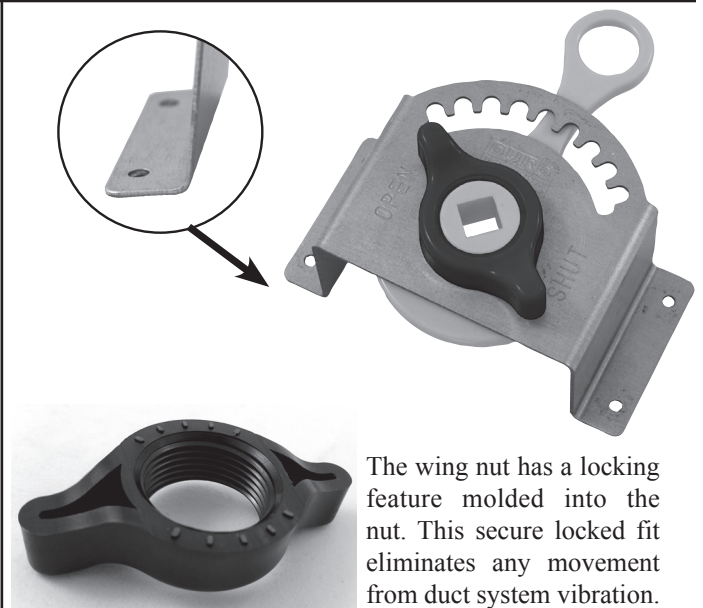

The wing nut has a locking feature molded into the nut. This secure locked fit eliminates any movement from duct system vibration.

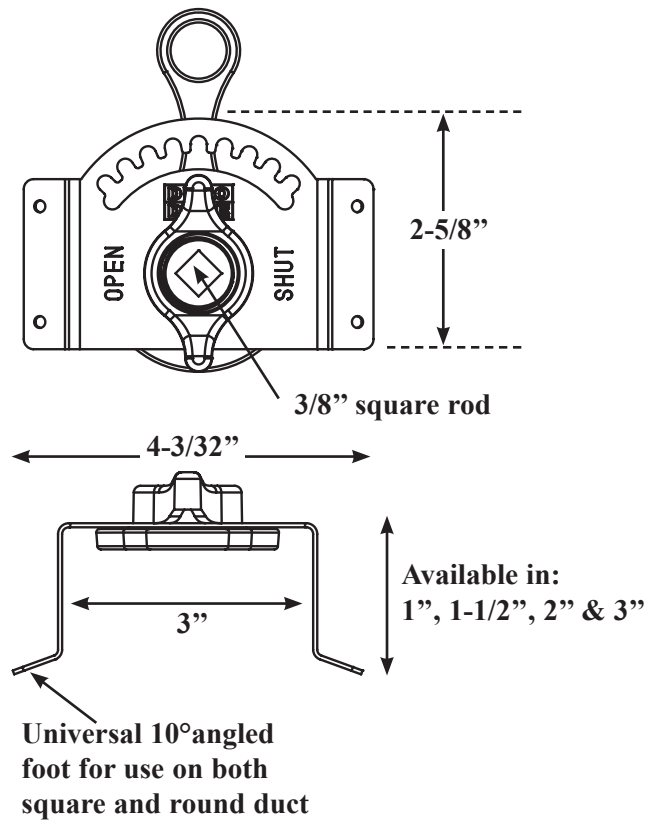

Materials

Bracket:

- 1.2 mm Steel – Cold Rolled Steel ASTM A-1008
- 18 gauge
- Hot dipped zinc galvanized steel.

Handle & Nut:

- Nylon 6.6
- Conforms to UL1995 Standards Code for Heating and Cooling CSA-C22.2 No. UL1995
- Flammability Rating: 5VA

DURO-TWIST*				
ITEM#	CODE	SHAFT SIZE	STAND HEIGHT	QTY
7071	DT38100B	3/8" sq.	1"	100
7072	DT38150B	3/8" sq.	1-1/2"	100
7073	DT38200B	3/8" sq.	2"	50
7075	DT38300B	3/8" sq.	3"	50

*Depending upon quantity, longer lead times may apply.

Duro Dyne East Division, Bay Shore, NY
 Duro Dyne Midwest Division, Hamilton, OH
 Duro Dyne West Division, Fontana, CA
 Duro Dyne Canada, Lachine, Quebec, Canada

631-249-9000 Fax: 631-249-8346
 513-870-6000 Fax: 513-870-6005
 562-926-1774 Fax: 562-926-5778
 514-422-9760 Fax: 514-636-0328

www.durodyne.com E-mail: durodyne@durodyne.com



©2016 Duro Dyne Corporation
 Printed in USA 10/18/16
 BO008463