



## FireMaster® DryerWrap

Datasheet Code US: 714-241

© 2014 Thermal Ceramics is a business of Morgan Advanced Materials



### 1. Product Description

Thermal Ceramics newest fire rated duct wrap product is FireMaster DryerWrap for application on dryer vent ductwork in multi-unit housing where fire compartmentation and life safety are major concerns. FireMaster DryerWrap is tested and UL Listed for 1-hour fire resistance on light gage construction up to 7" diameter or 10x4" rectangular duct penetrating 1-hour rated wood joist gypsum floor therefore providing Owners, Architects, and Engineers a viable and cost effective solution for safely routing dryer exhausts from the laundry room to the exit of the building. At 1/2" thick and 8 pound per cubic foot density, DryerWrap is 67% thinner, lighter, and appreciably more flexible than grease duct fire wraps currently available. The optimized thickness and approved 1" compression or overlap joints provide for significant installation cost and space savings.

### Product Features

- 1/2 inch thick, 8 lb per cubic foot density
- High temperature insulation rated for 2100°F continuous exposure
- Underwriters Laboratory tested and Listed per ISO6944 and ASTM E814 (UL1479)
- Fully Encapsulated in scrim reinforced foil facing
- 1 inch compression or overlap at joints allows for installation inside 5 inch space for typical 4 inch round duct
- Installation using 16 gage galvanized steel tie-wire
- Tested on 30 gage 7 inch round and 26 gage, 10x4 rectangular duct, typical of dryer and domestic kitchen range vent construction

### Product Benefits

- Optimized installation cost
- Optimized installation space
- Easily to cut
- More flexible than alternative wraps
- Improved safety with application specific testing

### 2. Physical Characteristics

Length x Width:	300 inches x 16 or 32 inches
Thickness:	1/2 inch
Density:	8 lb. per cubic foot
Encapsulation:	Scrim reinforced foil (FSP)
Packaging:	1 roll per carton
Blanket Weight:	11 lbs for 16 inch width, 22 lbs for 32 inch width

### 3. Performance Specification

ISO 6944	1-Hour Rating
ASTM E814 (UL1479)	1-Hour T-Rating
ASTM E814 (UL1479)	1-Hour F-Rating
ASTM E84 -Flame Spread	< 25
ASTM E84 -Smoke Developed	< 50
ASTM E136	Pass
ASTM C518 -R-Value at 70°F	2.4
ASTM D6329 (Mold at 75 R.H.)	Resistant

### 4. Codes Compliance and Laboratory Listings

2009 IBC Sections 716.6.2, 708, and 703  
 2009 IMC Section 504.2 and 604  
 UL Listing F-C-7055 and F-C-7059 for 1-Hour F-and T-Rating  
 UL Listing HNLJ.V-29 for 1-Hour Ventilation Duct Rating  
 ULC Listing FRD 28 for 1-Hour Ventilation Duct Rating

### 5. Installation

#### Materials and Equipment

- FireMaster DryerWrap
- 3" adhesive backed aluminum foil tape
- Serrated knife recommend
- 16 Gage galvanized steel tie-wire
- Wire cutters

Installation: Cut insulation to the length of the duct to be wrapped, and tape seal cut edges using 3" foil tape. For 4" dryer ducts the as supplied 16" width will be sufficient to provide for either a 1" compression or 1" overlap on the longitudinal joint. Ducts larger than 4" diameter can be wrapped using 32" wide DryerWrap utilizing a continuous wrap of duct lengths up to 25 ft and minimum 1" overlap around the circumference of the duct, or cut to length sufficient to wrap around duct with a joint every 32". This long joint may be tape sealed utilizing 3" foil tape at the contractors discretion. Adjacent blankets are installed with either a minimum 1" compression or 1" overlap at the joint between blankets. Utilizing minimum 16 gage tie-wire, cut wire to sufficient length to wrap the insulated duct and make a small loop in one end. Wrap the tie-wire around the insulated duct on maximum 12" centers. Where the insulated duct passes through 1-hour rated floor/ceiling assemblies, the penetration should be framed out and the annular space packed with scrap FireMaster insulation recessed minimum 1/4" from top surface. The recesses space shall be filled with a UL Listed firestop sealant per F-C-7055. Where the duct penetrates a membrane only, the maximum annular space and fill material shall be per F-C-7059.



**FireMaster® DryerWrap**

**DryerWrap for 1-Hour Enclosure of Dryer Vents**

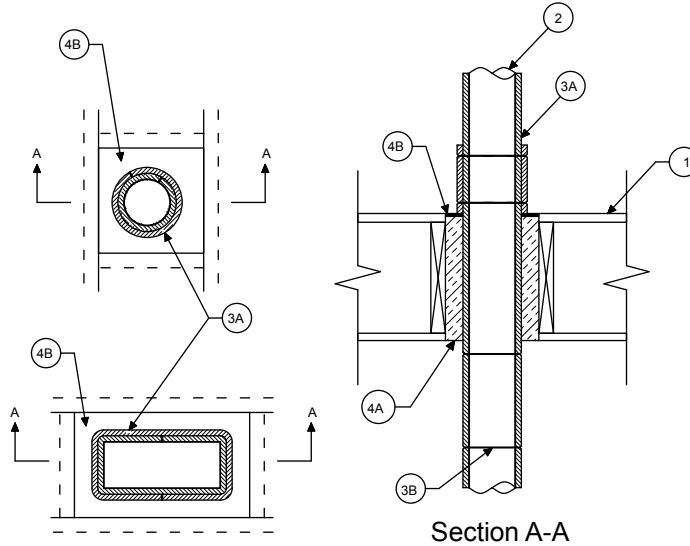

LEGEND	
1	1-Hour UL Listed Floor/Ceiling Assembly
2	Maximum 7" diameter, 30 gage or maximum 10x4" rect, 26 gage duct
3A	FireMaster DryerWrap with 1" longitudinal and transverse compression or overlap joints. Through Penetrations require a 12" long collar above the penetration.
3B	Minimum 16 Gage galvanized steel tie-wire installed on maximum 12" centers
4A	FireMaster blanket (For Through Penetrations) packed into annular space (25% min. compression)
4B	Firestop sealant per F-C-7055 or F-C-7059 (FireMaster Putty or approved alternative)

The integrity of FireMaster duct systems is limited to the quality of the installation.

UL Listings HNLJ.V-29  
ULC Listings FRD-28  
UL Listings F-C-7055  
UL Listings F-C-7059

**1-HR F AND T-RATING**

